



SCREWS

SCREWS MANUFACTURER

ONE-STOP HARDWARE SUPPLIER

NUWEN



+86-18680577977

Index

Screw Data	01
Collated Screw	03
Drywall Screw	05
Chipboard Screw	06
Self Drilling Screw CSK Head	07
Self Drilling Screw Pan Head	08
Self Drilling Screw Truss Head	09
Self Drilling Screw Wafer Head	10
Self Drilling Screw Hex Washer Head	11
Self Drilling Screw Hex Flange Head	12
Self Drilling Screw Hex Sandwich Screw	13
Farmer Screw	14
Self Drilling Screw Bugle Head	15
Self Drilling Screw Countersunk Wings	16
Diamond Head Concrete Screw	17
Self Tapping Screw Oval Head	18
Self Tapping Screw CSK Head	19
Self Tapping Screw Pan Head	20
Self Tapping Screw Truss Head	21
Self Tapping Screw Pan Framing Head	22
Self Tapping Screw Hex Washer Head	23
Wood Screw Hexagon Head	24
Wood Screw CSK Head	25
Confirmat Screw	26
Dowel Screw	27
Hanger Bolt	27
Concrete Screw	28
Machine Screw	28
Packaging & Shipping	29
About Us	30

+86-18680577977

Screw Data

Material



Carbon steel :
C-1022 Steel Case Hardened



Stainless steel:
201/ 304 / 316 / 316L



Brass



Titanium



Aluminum

Finishes



Black Phosphated



Grey Phosphated



White Blue Zinc Plated



Yellow Zinc Plated



White Zinc Plated



Black Zinc Plated

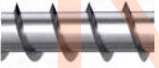

Nickel Plated

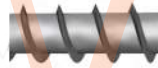

Hot Dip Galvanized



Black Oxide



Ruspert



Dacromet

Washer



P.V.C



E.P.D.M



Bonded Washer

Standard

- DIN
- ANSI
- JIS
- Customized
- GB
- ISO

Certification



CE Certificate | SGS Certificate | TÜV Certificate

Head Styles



Bugle



C.S.K



Double C.S.K



H.W.F



H.W.H



Hex



Cap



Oval



Pan



Pan Framing



Truss



Wafer



Hinge



Pancake



Round



Large Wafer

Head Recess



Phillip



Pozi



Frearson



Cross



Phillips/Slot



Slot



Square



Slot/Square



hexagon



Trangle



Torx-Tamper



Torx



Y-Type



Tri-Wing

Threads & Points



Die Point



Dog Point



Rolled



Pinch



Nail Point



Cupped



Round



Cone



Type-A



Type-B



Type-AB



Type-C



Type-F



Type-FZ



Type 1



Type-17



Type-23



Type-25



Drilling



Wing Tek's



Spoon

Collated Screw



Twinfast / Coarse thread

Bugle Head Drywall Screw

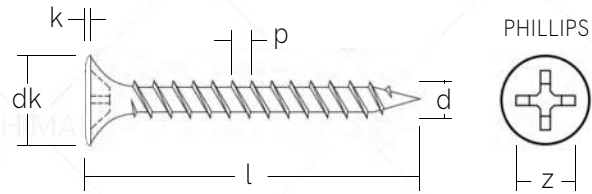

PHILLIPS

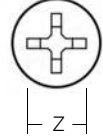

Size	3.5x	3.9x	4.8x	4.8x	#6x	#7x	#8x	#10x	Usual Data
(mm)	25	25	25	25	1"	1"	1"	1"	dk: 8-9.2
	32	32	32	32	1-1/4"	1-1/4"	1-1/4"	1-1/4"	p: 1.49-3.18
	38	38	38	38	1-1/2"	1-1/2"	1-1/2"	1-1/2"	k: 0.8
	50	50	50	50	2"	2"	2"	2"	z: No.2

NUWEN



Pozi Recess

Flat Head Chipboard Screw

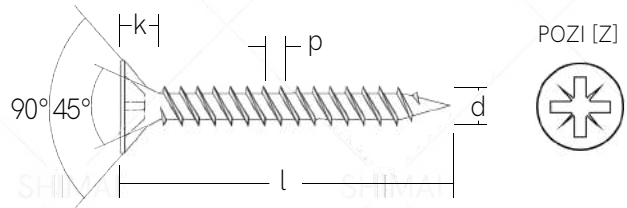

POZI [Z]



Size	4.5x	6.0x	#9x	#13x	Usual Data
(mm)	25	40	1"	1-5/8"	dk: 7.9-11.9
	30	50	1-3/16"	2"	p: 1.80-2.60
	35		1-3/8"		k: 4.25-6
	45		1-3/4"		

Collated Screw



Phillips Recess

Countersunk Head Self-Drilling Screw

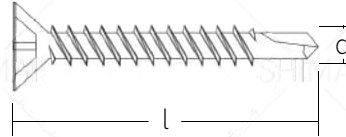

PHILLIPS



Size	3.5x	3.9x	4.2x	#6x	#7x	#8x	Usual Data
(mm)	<u>25</u>	<u>25</u>	<u>25</u>	<u>1"</u>	<u>1"</u>	<u>1"</u>	Point: #2, #3 application thickness: point #2 < 2 mm point #3 < 5 mm
		<u>32</u>	<u>32</u>		<u>1-1/4"</u>	<u>1-1/4"</u>	
		<u>38</u>	<u>38</u>		<u>1-1/2"</u>	<u>1-1/2"</u>	

NUWEN



Bugle Head

Drywall Self-Drilling Screw

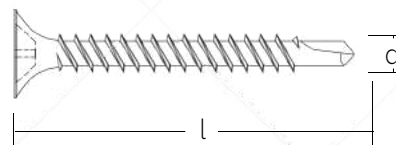

PHILLIPS



Size	3.5x	3.9x	4.2x	#6x	#7x	#8x	Usual Data
(mm)	<u>25</u>	<u>25</u>	<u>25</u>	<u>1"</u>	<u>1"</u>	<u>1"</u>	Point: #2, #3 Suggested application thickness: point #2 < 2 mm point #3 < 5 mm
	<u>28</u>	<u>32</u>	<u>32</u>	<u>1-1/8"</u>	<u>1-1/4"</u>	<u>1-1/4"</u>	
	<u>32</u>	<u>38</u>	<u>50</u>	<u>1-1/4"</u>	<u>1-1/2"</u>	<u>2"</u>	
	<u>41</u>	<u>50</u>	<u>60</u>	<u>1-5/8"</u>	<u>2"</u>	<u>2-3/8"</u>	
	<u>50</u>		<u>65</u>	<u>2"</u>		<u>2-5/8"</u>	

Drywall Screw



Twinfast Thread

Coarse Thread

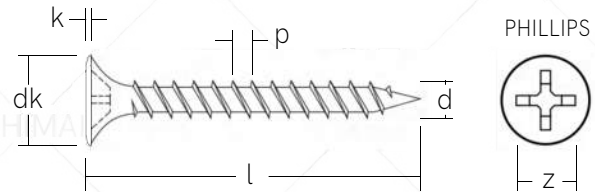

Phillips drive bugle Head Screw



Finishes

-  Black Phosphated
-  Grey Phosphated
-  Zinc Plated
-  Nickel Plated

Material

-  Carbon steel :
C-1022 Steel Case Hardened
-  Stainless steel:
201 / 304 / 316 / 316L

Usual Data

- d: M3.5-M4.8
- dk: 8-9.2
- k: 0.8
- z: No.2
- p: 1.49-3.18

Size	3.5x	3.9x	4.2x	4.8x	#6x	#7x	#8x	#10x
	13	20	13	51	1/2	3/4	1/2	2
	16	25	16	65	5/8	1	5/8	2-1/2
	19	30	19	70	3/4	1-1/8	3/4	2-3/4
	25	32	25	75	1	1-1/4	1	3
	29	35	32	90	1-1/8	1-1/2	1-1/4	3-1/2
	32	38	34	100	1-1/4	1-5/8	1-1/2	4
	35	40	38	115	1-3/8	1-3/4	1-5/8	4-1/2
(mm)	38	45	40	120	1-1/2	1-7/8	1-3/4	4-3/4
	41	51	51	125	1-5/8	2	2	5
	45	55	65	127	1-3/4	2-1/8	2-1/2	5-1/8
	51	65	70	150	2	2-1/2	2-3/4	6
	55	70	75	152	2-1/8	2-3/4	3	6-1/8
	57	75	90		2-1/4	3	3-1/2	
	60		102		2-3/8		4	
	65				2-1/2			
	70				2-3/4			
	75				3			

Chipboard Screw



Double CSK Head

CSK Head

Flat Head Chipboard Screw

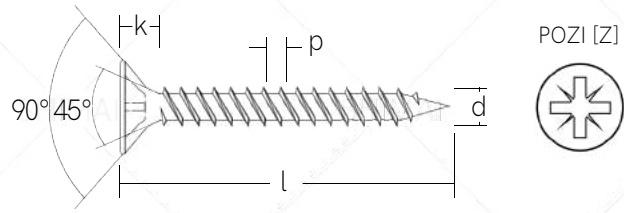

Finishes



Head Recess

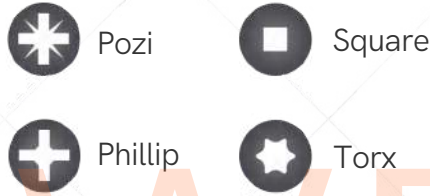

Usual Data

d: M3 - M6
 dk: 5.9 - 11.9
 k: 3.2 - 6
 z: 1, 2, 3
 p: 1.35 - 2.6

Size	3x	3.5x	4x	4.5x	5x	6x
	16	16	20	20	20	30
	20	17	25	25	25	40
	25	20	30	30	30	50
	30	25	35	35	35	60
	35	30	40	40	40	70
		35	45	50	45	80
		40	50	60	50	90
		45	60		60	100
		50			70	110
		55			80	120
					90	130
					100	140
					110	150
					120	160
						180
						200

(mm)

Self Drilling Screw



C1022(A)

SS

Phillips Flat / Countersunk(CSK) Head

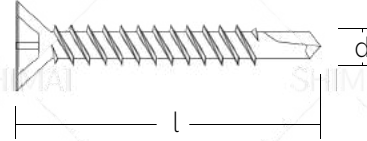

PHILLIPS



Finishes



Black Phosphated



Ruspert



White Blue Zinc Plated



Dacromet



Yellow Zinc Plated



Hot Dip Galvanized

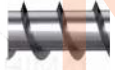

Nickel Plated

Usual Data

d: M3.5-M4.8
point: #2, #3

Suggested application thickness:
point #2 < 2 mm
point #3 < 5 mm

Applications

- Best choice for fastening in window or door frames purpose
- Using in flat surface required
- Using in per-drilled hole for fitting

Size	3.5x	3.9x	4.2x	4.8x	#6x	#7x	#8x	#10x
	<u>13</u>	<u>13</u>	<u>13</u>	<u>13</u>	<u>1/2"</u>	<u>1/2"</u>	<u>1/2"</u>	<u>1/2"</u>
	<u>16</u>	<u>16</u>	<u>16</u>	<u>16</u>	<u>5/8"</u>	<u>5/8"</u>	<u>5/8"</u>	<u>5/8"</u>
	<u>19</u>	<u>19</u>	<u>19</u>	<u>19</u>	<u>3/4"</u>	<u>3/4"</u>	<u>3/4"</u>	<u>3/4"</u>
(mm)	<u>25</u>	<u>25</u>	<u>25</u>	<u>25</u>	<u>1"</u>	<u>1"</u>	<u>1"</u>	<u>1"</u>
		<u>32</u>	<u>32</u>	<u>32</u>		<u>1-1/4"</u>	<u>1-1/4"</u>	<u>1-1/4"</u>
		<u>38</u>	<u>38</u>	<u>38</u>		<u>1-1/2"</u>	<u>1-1/2"</u>	<u>1-1/2"</u>
		<u>50</u>	<u>50</u>	<u>45</u>		<u>2"</u>	<u>2"</u>	<u>1-3/4"</u>
				<u>50</u>				<u>2"</u>
			<u>75</u>				<u>3"</u>	
				(inch)				

Self Drilling Screw



C1022(A)

SS

Phillips Pan Head

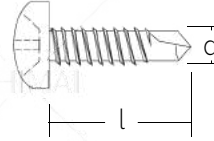

PHILLIPS

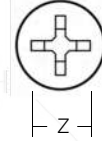

Finishes



Black Phosphated



Ruspert



White Blue Zinc Plated



Dacromet



Yellow Zinc Plated



Hot Dip Galvanized



Nickel Plated

Usual Data

d: M3.5-M4.8
point: #2, #3

Suggested application thickness:
point #2 < 2 mm
point #3 < 5 mm

Applications

- Residential steel frame construction
- Skin sheet to steel
- For light duty purpose
- Suitable for stitching 1 thick & 1 thin steel plate

Size	3.5x	3.9x	4.2x	4.8x	#6x	#7x	#8x	#10x
	<u>13</u>	<u>13</u>	<u>13</u>	<u>13</u>	<u>1/2"</u>	<u>1/2"</u>	<u>1/2"</u>	<u>1/2"</u>
	<u>16</u>	<u>16</u>	<u>16</u>	<u>16</u>	<u>5/8"</u>	<u>5/8"</u>	<u>5/8"</u>	<u>5/8"</u>
	<u>19</u>	<u>19</u>	<u>19</u>	<u>19</u>	<u>3/4"</u>	<u>3/4"</u>	<u>3/4"</u>	<u>3/4"</u>
(mm)	<u>25</u>	<u>25</u>	<u>25</u>	<u>25</u>	<u>1"</u>	<u>1"</u>	<u>1"</u>	<u>1"</u>
		<u>32</u>	<u>32</u>	<u>32</u>		<u>1-1/4"</u>	<u>1-1/4"</u>	<u>1-1/4"</u>
		<u>38</u>	<u>50</u>	<u>38</u>		<u>1-1/2"</u>	<u>2"</u>	<u>1-1/2"</u>
		<u>50</u>		<u>45</u>		<u>2"</u>		<u>1-3/4"</u>
				<u>50</u>				<u>2"</u>
			<u>75</u>					<u>3"</u>
					(inch)			

Self Drilling Screw



C1022(A)



SS

Phillips Truss Head

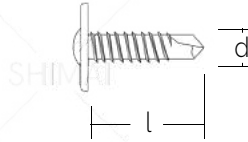

PHILLIPS



Finishes



Black Phosphated



Ruspert



White Blue Zinc Plated



Dacromet



Yellow Zinc Plated



Hot Dip Galvanized



Nickel Plated

Usual Data

d: M3.9-M4.2
point: #2, #3

Suggested application thickness:
point #2 < 2 mm
point #3 < 5 mm

Applications

- Residential steel frame construction
- For using in object like polycarbonate sheet, shadow cover

Size	3.9x	4.2x	#7x	#8x
	<u>13</u>	<u>13</u>	<u>1/2"</u>	<u>1/2"</u>
	<u>16</u>	<u>16</u>	<u>5/8"</u>	<u>5/8"</u>
	<u>19</u>	<u>19</u>	<u>3/4"</u>	<u>3/4"</u>
(mm)	<u>25</u>	<u>25</u>	<u>1"</u>	<u>1"</u>
	<u>32</u>	<u>32</u>	<u>1-1/4"</u>	<u>1-1/4"</u>
	<u>38</u>	<u>38</u>	<u>1-1/2"</u>	<u>1-1/2"</u>
	<u>45</u>	<u>45</u>	<u>1-3/4"</u>	<u>1-3/4"</u>
	<u>50</u>	<u>50</u>	<u>2"</u>	<u>2"</u>
			(inch)	

Self Drilling Screw



C1022(A)



SS

Wafer / Pan Framing Head

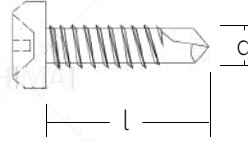

PHILLIPS



Finishes



Black Phosphated



Ruspert



White Blue Zinc Plated



Dacromet



Yellow Zinc Plated



Hot Dip Galvanized



Nickel Plated

Usual Data

d: M3.5-M3.9
point: #2, #3

Suggested application thickness:
point #2 < 2 mm
point #3 < 5 mm

Applications

- Roof and skin sheet to steel
- Residential steel frame construction
- For light duty purpose

Size	3.5x	3.9x	#6x	#7x
	<u>9.5</u>	<u>9.5</u>	<u>3/8"</u>	<u>3/8"</u>
	<u>11</u>	<u>11</u>	<u>7/16"</u>	<u>7/16"</u>
(mm)	<u>13</u>	<u>13</u>	<u>1/2"</u>	<u>1/2"</u>
		<u>16</u>		<u>5/8"</u>
			(inch)	

Self Drilling Screw



C1022(A)

SS

Hex Washer Head

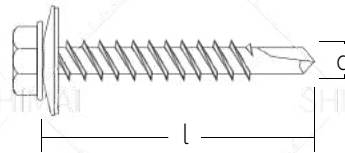

Hex head



Finishes

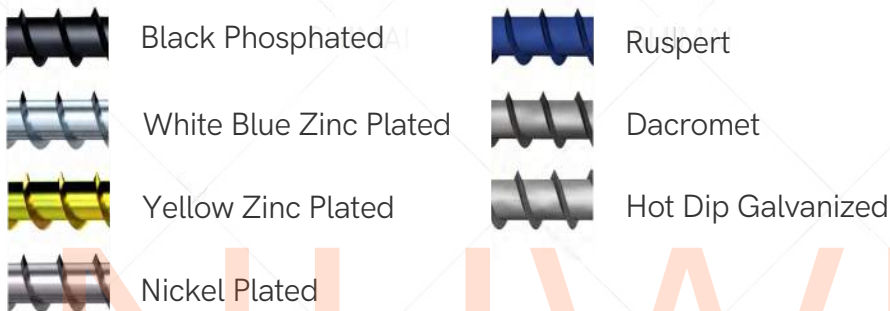

Usual Data

d: M4.2-M6.3
 point: #2, #3, #4, #5
 Application thickness:
 point #2 < 2 mm
 point #3 < 5 mm
 point #4 < 8 mm
 point #5 < 12 mm

Size	4.2x	4.8x	5.5x	6.3x	#8x	#10x	#12x	#14x
	13	13	19	19	1/2"	1/2"	3/4"	3/4"
	16	16	25	25	5/8"	5/8"	1"	1"
	19	19	32	32	3/4"	3/4"	1-1/4"	1-1/4"
	25	25	35	38	1"	1"	1-3/8"	1-1/2"
	32	32	38	41	1-1/4"	1-1/4"	1-1/2"	41
	38	38	41	50	1-1/2"	1-1/2"	1-5/8"	2"
		45	45	63		1-3/4"	1-3/4"	2-1/2"
		50	50	75		2"	2"	3"
(mm)			55	80	(inch)		2-1/8"	3-1/5"
			63	90			2-1/2"	3-1/2"
			65	100			3"	4"
			75	115			3-1/5"	4-1/2"
			80	125			3-1/2"	5"
			90	135			4"	5-2/5"
			100	150			4-1/2"	6"
			115	165			5"	6-3/5"
			125				5-2/5"	
			135				6"	
			150				6-3/5"	
			165					

Self Drilling Screw



C1022(A)

SS

Hex Flange Head

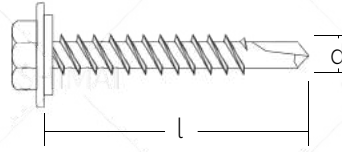

Flange head

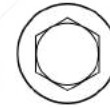

Finishes



Black Phosphated



Ruspert



White Blue Zinc Plated



Dacromet



Yellow Zinc Plated



Hot Dip Galvanized

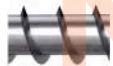

Nickel Plated

Usual Data

d: M4.2-M6.3

point: #2, #3, #4, #5

Application thickness:

point #2 < 2 mm

point #3 < 5 mm

point #4 < 8 mm

point #5 < 12 mm

Size	4.2x	4.8x	5.5x	6.3x	#8x	#10x	#12x	#14x
	13	13	19	19	1/2"	1/2"	3/4"	3/4"
	16	16	25	25	5/8"	5/8"	1"	1"
	19	19	32	32	3/4"	3/4"	1-1/4"	1-1/4"
	25	25	35	38	1"	1"	1-3/8"	1-1/2"
	32	32	38	41	1-1/4"	1-1/4"	1-1/2"	41
	38	38	41	50	1-1/2"	1-1/2"	1-5/8"	2"
		45	45	63		1-3/4"	1-3/4"	2-1/2"
		50	50	75		2"	2"	3"
(mm)			55	80	(inch)		2-1/8"	3-1/5"
			63	90			2-1/2"	3-1/2"
			65	100			3"	4"
			75	115			3-1/5"	4-1/2"
			80	125			3-1/2"	5"
			90	135			4"	5-2/5"
			100	150			4-1/2"	6"
			115	165			5"	6-3/5"
			125				5-2/5"	
			135				6"	
			150				6-3/5"	
			165					

Self Drilling Screw



Sandwich Screw

Double Thread

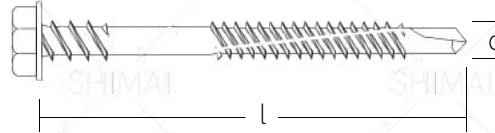

Hex head



Finishes



Black Phosphated



Ruspert



White Blue Zinc Plated



Dacromet



Yellow Zinc Plated

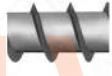

Hot Dip Galvanized



Nickel Plated

Usual Data

d: M4.2-M6.3

point: #3, #4, #5

Suggested application thickness:

point #3 < 5 mm

point #4 < 8 mm

point #5 < 12 mm

Applications

- Roof and wall panel over rigid insulation to steel framing
- Roof panel over spacer block and insulation to eaves purlin

Size	5.5x	6.3x	#12x	#14x
	<u>60</u>	<u>60</u>	<u>2-3/8"</u>	<u>2-3/8"</u>
	<u>80</u>	<u>80</u>	<u>3-5/32"</u>	<u>3-5/32"</u>
	<u>100</u>	<u>100</u>	<u>4"</u>	<u>4"</u>
	<u>125</u>	<u>125</u>	<u>5"</u>	<u>5"</u>
(mm)	<u>150</u>	<u>150</u>	<u>6"</u>	<u>6"</u>
		<u>175</u>		<u>7"</u>
		<u>200</u>		<u>8"</u>
		<u>250</u>		<u>10"</u>
		<u>275</u>		<u>11"</u>

(inch)

Self Drilling Screw



Color Painted

Farmer Screws

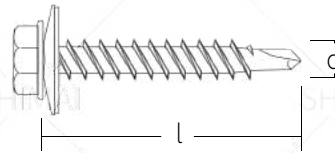

Hex head



PAL Colors

Usual Data



d: M4.8-M6.3
point: #2

Suggested application
thickness:
Reduced
point < 1.6 mm

Size	4.8x	5.5x	6.3x	#10x	#12x	#14x
	13	19	19	1/2"	3/4"	3/4"
	16	25	25	5/8"	1"	1"
	19	32	32	3/4"	1-1/4"	1-1/4"
	25	38	38	1"	1-1/2"	1-1/2"
	32	41	41	1-1/4"	1-3/4"	41
	35	50	50	1-3/8"	2"	2"
	38	63	63	1-1/2"	2-1/2"	2-1/2"
	45	75	75	1-3/4"	3"	3"
	50	80	80	2"	3-1/5"	3-1/5"
		90	90		3-1/2"	3-1/2"
		100	100		4"	4"
		115	115		4-1/2"	4-1/2"
		125	125		5"	5"
		135	135		5-2/5"	5-2/5"
		150	150		6"	6"
		165	165		6-3/5"	6-3/5"

Self Drilling Screw



C1022(A)

SS

Phillips Bugle Head

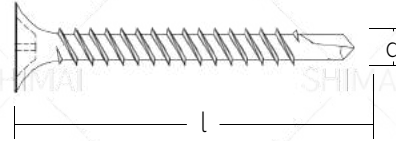

PHILLIPS



Finishes



Black Phosphated



Ruspert



White Blue Zinc Plated



Dacromet



Yellow Zinc Plated

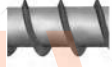

Hot Dip Galvanized



Nickel Plated

Usual Data

d: M3.5-M4.2
point: #2, #3

Suggested application thickness:
point #2 < 2 mm
point #3 < 5 mm

Applications

- For using in stitch wood to metal
- Using in pre-drilled hole for fitting
- Using in flat surface required

Size	3.5x	4.2x	#6x	#8x
	<u>25</u>	<u>25</u>	<u>1"</u>	<u>1"</u>
	<u>28</u>	<u>32</u>	<u>1-1/8"</u>	<u>1-1/4"</u>
	<u>32</u>	<u>38</u>	<u>1-1/4"</u>	<u>1-1/2"</u>
	<u>38</u>	<u>50</u>	<u>1-1/2"</u>	<u>2"</u>
	<u>41</u>	<u>60</u>	<u>1-5/8"</u>	<u>2-3/8"</u>
	<u>50</u>	<u>65</u>	<u>2"</u>	<u>2-5/8"</u>
		<u>75</u>		<u>3"</u>
(mm)			(inch)	

Self Drilling Screw



C1022(A)

SS

Countersunk Wings

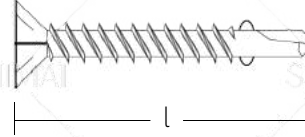

PHILLIPS



Finishes



Black Phosphated



Ruspert



White Blue Zinc Plated



Dacromet



Yellow Zinc Plated



Hot Dip Galvanized



Nickel Plated

Usual Data

d: M4.8 - M6.3
 point: #3, #4, #5
 Suggested application thickness:
 point #3 < 5 mm
 point #4 < 8 mm
 point #5 < 12 mm

Applications

- Wood mansard to steel frames
- Plywood fascial to steel frames
- Plywood roof and floor sheet to steel frames

Size	3.9x	4.8x	5.5x	6.3x	#7x	#10x	#12x	#14x
	<u>19</u>	<u>25</u>	<u>38</u>	<u>50</u>	<u>3/4"</u>	<u>1"</u>	<u>1-1/2"</u>	<u>2"</u>
	<u>25</u>	<u>32</u>	<u>50</u>	<u>80</u>	<u>1"</u>	<u>1-1/4"</u>	<u>2"</u>	<u>3-5/32"</u>
	<u>28</u>	<u>38</u>	<u>55</u>	<u>88</u>	<u>1-1/8"</u>	<u>1-1/2"</u>	<u>2-3/16"</u>	<u>3-1/2"</u>
(mm)	<u>32</u>	<u>45</u>	<u>75</u>	<u>120</u>	(inch)	<u>1-1/4"</u>	<u>1-3/4"</u>	<u>3"</u>
	<u>38</u>		<u>80</u>	<u>150</u>		<u>1-1/2"</u>	<u>3-5/32"</u>	<u>6"</u>
	<u>45</u>		<u>88</u>			<u>1-3/4"</u>	<u>3-1/2"</u>	
			<u>120</u>				<u>4-3/4"</u>	

Self Drilling Screw



Ruspert Diamond Head Screws

Concrete & Masonry Application

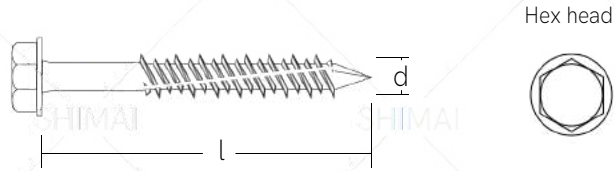

Applications

- Concrete material fixtures
- Flexible flashing
- Suitable for soft brick & masonry work

Features

- Can be using in exterior environment
- Internal washer design provides more bearing surface
- Hi-lo thread provides smooth power for drilling
- Pre-drilled hole are requested

NUWEN

Size	5.5x	6.3x	#12x	#14x
	<u>60</u>	<u>60</u>	<u>2-3/8"</u>	<u>2-3/8"</u>
	<u>80</u>	<u>75</u>	<u>3-5/32"</u>	<u>3"</u>
	<u>100</u>	<u>80</u>	<u>4"</u>	<u>3-5/32"</u>
(mm)	<u>125</u>	<u>90</u>	<u>5"</u>	<u>3-1/2"</u>
	<u>150</u>	<u>100</u>	<u>6"</u>	<u>4"</u>
		<u>125</u>		<u>5"</u>
		<u>140</u>		<u>5-1/2"</u>
		<u>160</u>		<u>6-5/16"</u>
		<u>180</u>		<u>7-1/8"</u>
		<u>200</u>		<u>7-7/8"</u>
			(inch)	

Self Tapping Screw



C1022(A)

SS

Oval Head Self-Tapping Screw

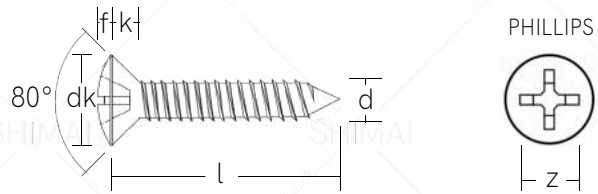

Finishes

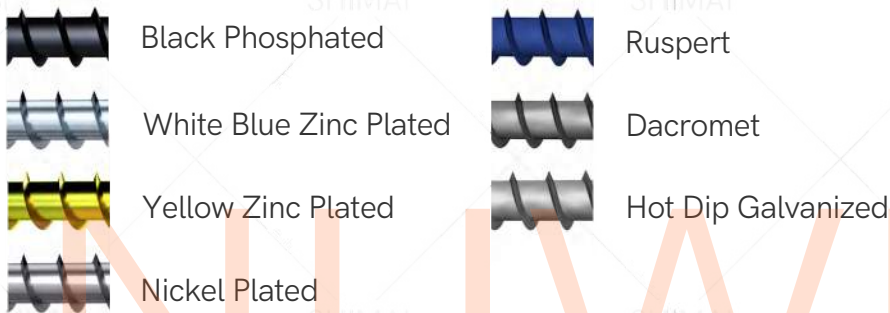

Usual Data

d: M3.5 - M4.8
 l: 16mm - 50mm
 dk: 6.44 - 9.50
 k: 2.1 - 3.0
 f: 1.2 - 1.5

Head Recess

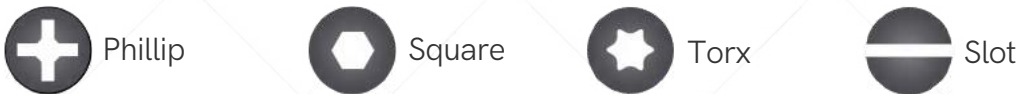

Size	3.5x	3.9x	4.2x	4.8x	#6x	#7x	#8x	#10x
(mm)	13	13	13	13	1/2"	1/2"	1/2"	1/2"
	16	16	16	16	5/8"	5/8"	5/8"	5/8"
	19	19	19	19	3/4"	3/4"	3/4"	3/4"
	25	25	25	25	1"	1"	1"	1"
		32	32	32		1-1/4"	1-1/4"	1-1/4"
		38	38	38		1-1/2"	1-1/2"	1-1/2"
		50	50	45		2"	2"	1-3/4"
			50					2"
			75					3"
(inch)								

Self Tapping Screw



C1022(A)

SS

Flat Head Self Tapping Screw

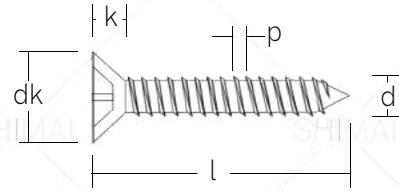

PHILLIPS



Finishes



Black Phosphated



Ruspert



White Blue Zinc Plated



Dacromet



Yellow Zinc Plated



Hot Dip Galvanized



Nickel Plated

Usual Data

d: M3.5 - M6.3

l: 9.5mm - 75mm

dk: 6.44 - 12.4

k: 2.1 - 3.8

Head Recess



Phillip



Square



Torx

Size	3.5x	3.9x	4.2x	4.8x	#6x	#7x	#8x	#10x
	<u>13</u>	<u>13</u>	<u>13</u>	<u>13</u>	<u>1/2"</u>	<u>1/2"</u>	<u>1/2"</u>	<u>1/2"</u>
	<u>16</u>	<u>16</u>	<u>16</u>	<u>16</u>	<u>5/8"</u>	<u>5/8"</u>	<u>5/8"</u>	<u>5/8"</u>
	<u>19</u>	<u>19</u>	<u>19</u>	<u>19</u>	<u>3/4"</u>	<u>3/4"</u>	<u>3/4"</u>	<u>3/4"</u>
(mm)	<u>25</u>	<u>25</u>	<u>25</u>	<u>25</u>	<u>1"</u>	<u>1"</u>	<u>1"</u>	<u>1"</u>
		<u>32</u>	<u>32</u>	<u>32</u>		<u>1-1/4"</u>	<u>1-1/4"</u>	<u>1-1/4"</u>
		<u>38</u>	<u>38</u>	<u>38</u>		<u>1-1/2"</u>	<u>1-1/2"</u>	<u>1-1/2"</u>
		<u>50</u>	<u>50</u>	<u>45</u>		<u>2"</u>	<u>2"</u>	<u>1-3/4"</u>
			<u>50</u>					<u>2"</u>
			<u>75</u>					<u>3"</u>
(inch)								

Self Tapping Screw



C1022(A)



SS

Pan Head Self Tapping Screw

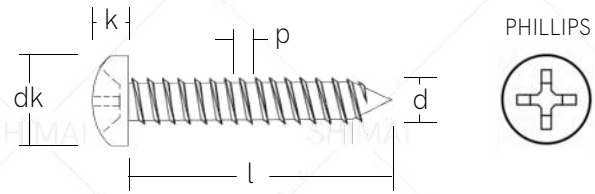

Finishes



Black Phosphated



Ruspert



White Blue Zinc Plated



Dacromet



Yellow Zinc Plated



Hot Dip Galvanized



Nickel Plated

Usual Data

d: M3.5 - M4.8

l: 13mm - 50mm

dk: 6.9 - 12.5

k: 1.5 - 3.65

Head Recess



Phillip



Phillips/Slot



Square



Torx



Slot

Size	3.5x	3.9x	4.2x	4.8x	#6x	#7x	#8x	#10x
	13	13	13	13	1/2"	1/2"	1/2"	1/2"
	16	16	16	16	5/8"	5/8"	5/8"	5/8"
	19	19	19	19	3/4"	3/4"	3/4"	3/4"
(mm)	25	25	25	25	1"	1"	1"	1"
		32	32	32		1-1/4"	1-1/4"	1-1/4"
		38	50	38		1-1/2"	2"	1-1/2"
		50		45		2"		1-3/4"
				50				2"
			75				3"	

Self Tapping Screw

Truss Head Self-Tapping Screw



Truss Head

Button Head

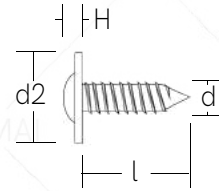

PHILLIPS



Finishes

Usual Data



Black Phosphated



Ruspert



White Blue Zinc Plated



Dacromet



Yellow Zinc Plated

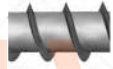

Hot Dip Galvanized

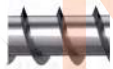

Nickel Plated

d: M3.9 - M4.2

l: 13mm - 50mm

d2: 11.5

H: 2.6

Size

3.9x

4.2x

#7x

#8x

(mm)

13
16
19
25
32
38
45
50

13
16
19
25
32
38
45
50

(inch)

1/2"
5/8"
3/4"
1"
1-1/4"
1-1/2"
1-3/4"
2"

1/2"
5/8"
3/4"
1"
1-1/4"
1-1/2"
1-3/4"
2"

Self Tapping Screw

Wafer / Pan Framing Head



C1022(A)

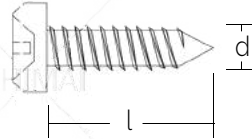







PHILLIPS

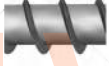

Finishes

Usual Data

- | | | | |
|---|------------------------|--|--------------------|
|  | Black Phosphated |  | Ruspert |
|  | White Blue Zinc Plated |  | Dacromet |
|  | Yellow Zinc Plated |  | Hot Dip Galvanized |
|  | Nickel Plated | | |

- d: M3.5 - M4.8
- l: 13mm - 50mm
- dk: 6.9 - 12.5
- k: 1.5 - 3.65

Size	3.5x	3.9x	#6x	#7x
(mm)	<u>9.5</u>	<u>9.5</u>	<u>3/8"</u>	<u>3/8"</u>
	<u>11</u>	<u>11</u>	<u>7/16"</u>	<u>7/16"</u>
	<u>13</u>	<u>13</u>	<u>1/2"</u>	<u>1/2"</u>
		<u>16</u>		<u>5/8"</u>
			(inch)	

Self Tapping Screw



Hex Washer Head

Hex Washer Head Self Tapping Screw

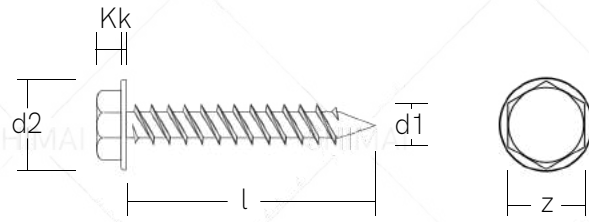

Finishes

Usual Data

- | | | | |
|--|------------------------|--|--------------------|
| | Black Phosphated | | Ruspert |
| | White Blue Zinc Plated | | Dacromet |
| | Yellow Zinc Plated | | Hot Dip Galvanized |
| | Nickel Plated | | |

- d1: M4.2 - M6.3
- l: 13mm - 165mm
- d2: 9.8 - 13.2
- K: 4.15 - 6.45
- k: 0.9 - 1

Size	4.2x	4.8x	5.5x	6.3x	#8x	#10x	#12x	#14x
	13	13	19	19	1/2"	1/2"	3/4"	3/4"
	16	16	25	25	5/8"	5/8"	1"	1"
	19	19	32	32	3/4"	3/4"	1-1/4"	1-1/4"
	25	25	35	38	1"	1"	1-3/8"	1-1/2"
	32	32	38	41	1-1/4"	1-1/4"	1-1/2"	41
	38	38	41	50	1-1/2"	1-1/2"	1-5/8"	2"
		45	45	63		1-3/4"	1-3/4"	2-1/2"
		50	50	75		2"	2"	3"
(mm)			55	80	(inch)		2-1/8"	3-1/5"
			63	90			2-1/2"	3-1/2"
			65	100			3"	4"
			75	115			3-1/5"	4-1/2"
			80	125			3-1/2"	5"
			90	135			4"	5-2/5"
			100	150			4-1/2"	6"
			115	165			5"	6-3/5"
			125				5-2/5"	
			135				6"	
			150				6-3/5"	
			165					

Wood Screw



Carbon steel

SS

Hexagon Head Wood Screw

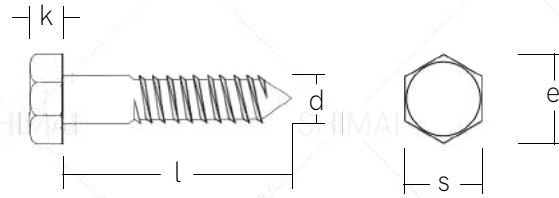

Material

Usual Data



Carbon steel



Stainless steel:
201 / 304 / 316 / 316L

k: 4 - 8.2
s: 10 - 19
d: M3.5 - M4.8

Size	6x	8x	10x	12x	1/4x	5/16x	3/8x
	30	40	40	70	3/4"	1"	1-3/16"
	40	50	50	80	1"	1-3/16"	1-3/8"
	50	60	60	100	1-3/16"	1-3/8"	1-5/8"
	60	70	70	120	1-3/8"	1-5/8"	1-3/4"
	70	80	80	140	1-5/8"	1-3/4"	2"
	80	90	90	150	1-3/4"	2"	2-3/16"
	90	100	100	160	2"	2-3/16"	2-3/8"
(mm)	100	110	120	180	2-3/16"	2-3/8"	2-1/2"
	110	120	130	200	2-3/8"	2-1/2"	2-3/4"
	120	130	140	220		2-3/4"	3"
	130	140	150	240		3"	3-5/2"
	140	150	160	260		3-3/52"	3-1/2"
	150	160	180	280		3-1/2"	4"
		170	200	300		4"	4-3/4"
		180	220	350			5-1/2"
		190	240	400			
		200	260				
			280				
			300				

Wood Screw



Carbon Steel

Brass

Flat Head Wood Screw

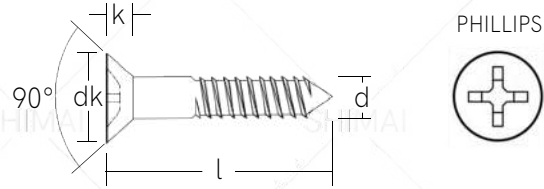

Material



Carbon steel



Stainless steel:
201 / 304 / 316 / 316L



Brass

Head Recess



Philip



Slot



Square

Usual Data

d: 4 - 6
l: 16 - 90
dk: 7.05 - 11.55
k: 2.2 - 3.0

Size	4x	5x	6x	#8x	#10x	#12x
	<u>16</u>	<u>16</u>	<u>25</u>	<u>5/8"</u>	<u>5/8"</u>	<u>1"</u>
	<u>20</u>	<u>20</u>	<u>30</u>	<u>3/4"</u>	<u>3/4"</u>	<u>1-3/16"</u>
	<u>25</u>	<u>25</u>	<u>35</u>	<u>1"</u>	<u>1"</u>	<u>1-3/8"</u>
	<u>30</u>	<u>30</u>	<u>40</u>	<u>1-3/16"</u>	<u>1-3/16"</u>	<u>1-5/8"</u>
	<u>35</u>	<u>35</u>	<u>45</u>	<u>1-3/8"</u>	<u>1-3/8"</u>	<u>1-3/4"</u>
	<u>40</u>	<u>40</u>	<u>50</u>	<u>1-5/8"</u>	<u>1-5/8"</u>	<u>2"</u>
	<u>45</u>	<u>45</u>	<u>60</u>	<u>1-3/4"</u>	<u>1-3/4"</u>	<u>2-3/8"</u>
(mm)	<u>50</u>	<u>50</u>	<u>70</u>	<u>2"</u>	<u>2"</u>	<u>2-3/4"</u>
	<u>60</u>	<u>60</u>	<u>80</u>	<u>2-3/8"</u>	<u>2-3/8"</u>	<u>3-3/52"</u>
		<u>70</u>	<u>90</u>		<u>2-3/4"</u>	<u>3-1/2"</u>
		<u>80</u>			<u>3-3/52"</u>	
				(inch)		

Confirmat Screw



Carbon steel

Hex, Phillips or Torx Recess

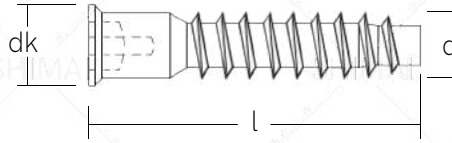

HEXAGON



Head Recess



Phillip



Pozi



Hexagon

Size	d x l	d	l	dk	s
	5 x 20	5	20	7.3 - 7.5	3
	5 x 25	5	25	7.3 - 7.5	3
	5 x 30	5	30	7.3 - 7.5	3
	5 x 40	5	40	7.3 - 7.5	3
	5 x 50	5	50	7.3 - 7.5	3
	6.3 x 30	6.3	30	9.3 - 10	4
	6.3 x 40	6.3	40	9.3 - 10	4
	6.3 x 50	6.3	50	9.3 - 10	4
	6.3 x 60	6.3	60	9.3 - 10	4
	7 x 30	7	30	10	4
	7 x 40	7	40	10	4
	7 x 50	7	50	10	4
	7 x 60	7	60	10	4
	7 x 70	7	70	10	4

(mm)

Dowel Screws

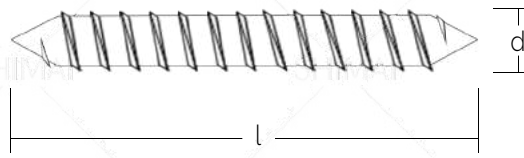

Size	d	l
(mm)	M4	25-70
	M5	25-70
	M6	25-100
	M8	25-100
	M10	25-100

NUWEN

Hanger Bolt

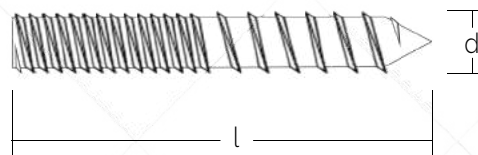

Size	d	l	pinch
(mm)	M4	25-70	0.7
	M5	25-70	0.8
	M6	25-100	1.0
	M8	25-100	1.25
	M10	25-100	1.5

Concrete Screw



Concrete Screw

Flat Torx Head Hi-Lo Thread

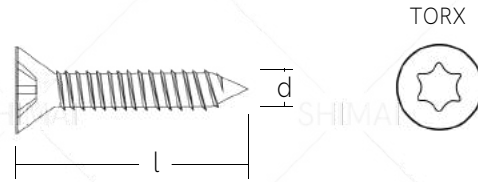

Size	d	l
7.5 x 60	7.5	72
7.5 x 92	7.5	112
7.5 x 132	7.5	152
7.5 x 182	7.5	212

(mm)

NUWEN

Machine Screws



Machine Screw

Flat Head Machine Screw

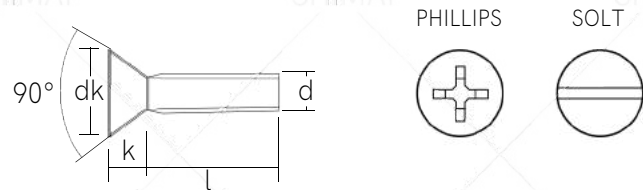

Size	d	l	dk	k
M3.5		13-100	6.5	1.93
M4		13-100	7.5	2.20
M5		13-100	9.2	2.5

(mm)

Packaging & Shipping



Color box



White box



Brown box

About delivery

For drywall screw orders with a total order of less than 30 tons, if there are no special circumstances, we will ship within 20 days after ordering

Packaging details

1. We have several sizes of packing dimensions, can be 20kg or 25kg per carton.
2. For large orders, we can design specific sizes of boxes and cartons.
3. Normal Packing: 1000pcs/500pcs/250pcs per small box. then small boxes into cartons.
4. Can provide special packings as middle east clients requests.



NUWEN CO.,LTD

Add:Unit 1,no.187,Xiayang road,Hetang Town Pengjiang District,Jiangmen City,Guangdong ,Province , China.

E-mail: nuwen.china.2020@gmail.com

Mobile: +86-18680577977

WeChat/Whats app: +86-18680577977



+86-18680577977